

## Design, Construction and Performance Test of a Color Detective Device

Md. Abdullah Al Mamun<sup>1</sup>, Md. Hasan Ali<sup>2</sup>, Md. Shafiul Ferdous<sup>3</sup>

<sup>1</sup>Graduate School of ME, Khulna University of Engineering and Technology, Khulna, Bangladesh

<sup>2</sup>Department of IPE, Bangladesh Army University of Science and Technology, Saidpur, Bangladesh

<sup>3</sup>Department of ME, Bangladesh Army University of Science and Technology, Saidpur, Bangladesh

<sup>1</sup>mamun.abdullahme@gmail.com, <sup>2</sup>hasankuet38@gmail.com, <sup>3</sup>munazeer\_218@yahoo.com

### Abstract

*In this universe every single component is colorful and it is necessary to know the color of each object. Though human beings can detect the color of the object by their natural visioning sense but in modern technology it is necessitated to sense the color artificially. A color sensor module like GY-31 TCS3200 and Arduino Uno is designed to detect the color of light incident on it. Color sensors play a significant role in end equipment such as color-monitor calibration, color printers and plotters, paints, textiles, cosmetics manufactures and medical applications such as blood diagnostics, urine analysis and dental matching as well as in light emitting diode (LED) sorting and testing, industrial sorting and identification, process control in labeling etc. So, it is necessary to know about the color sensor as well as how it works for vast application in modern technology and in industries.*

Keywords: Color Sensor, Arduino Uno, Sensor Module, Light-to-Frequency Converters.

### 1. Introduction

Light and color are mutually interrelated and light is nothing but an electromagnetic radiation. The human eye is sensitive to a narrow band of electromagnetic radiation that lies in the wavelength range between 400 and 700 nanometers, commonly known as the visible light spectrum. The mechanism by which visible light is emitted or absorbed by substances and react under different conditions when, it travels through space and the atmosphere from the basis of the existence of the color in our universe. In human color vision the first step is the sensory process that are the stimulation of light receptors in the eyes, conversion of the light stimuli or images into signals and transmission of electrical signals containing the vision information from each eye to the brain through the optic nerves. This information is processed in several stages, ultimately reaching to the visual cortices of the cerebrum. The colors red, green and blue are defined as the primary colors because they are fundamental to human vision. Light is perceived as white by human beings when all three cone cell types are simultaneously stimulated by equal amounts of red, green and blue light. When any object absorbs all the wavelength of light then it is called as colorless or dark object. In this universe every single component is colorful and it is necessary to know that which object is in which color. Though human beings can detect the color of the object by their natural visioning sense but in modern technology it is necessitated to sense the color artificially. That's why it comes into consideration to use the color detecting device or color sensor. Color detecting devise is to detect the color of any object. It works based on the fundamental of optics and digital electronics. Historically, components used for color sensing were considered expensive and required precision support circuitry, limiting their application mostly to specialized instrumentation. However, new technologies of color sensors with higher level of integration are becoming available, allowing for more cost effective solutions. As cost of color sensing comes down, the number of applications using color sensing is increased. Color sensors play a significant role in end equipment such as color-monitor calibration, color printers and plotters, paints, textiles, cosmetics manufactures and medical applications such as blood diagnostics, urine analysis and dental matching. This technique also can be used in such as light emitting diode (LED) sorting and testing, industrial sorting and identification, process control in labeling etc. That's why, it is necessary to know about the color sensor as well as how it works for it's vast application in modern technology and in industries. In this case this study will be helpful to know about a color detecting device.

### 2. Literature review

The detection and classification of local structures (i.e. edges, corners, and T-Junctions) in color images is important for many applications such as image segmentation, image matching, object recognition, visual

tracking in the fields of image processing and computer vision [1], [2], [3]. In general, those local image structures are detected by differential operators which are commonly restricted to luminance information. However, most of the images recorded today are in color. Therefore, the focus is on the use of color information to detect and classify local image features. A common requirement in the field of color sensing is that of color identification or sorting of objects by colors. Color sensor systems are increasingly being used in automated applications to detect automation errors and monitor quality at the speed of production line. They are used in assembly lines to identify and classify products by color [4]. A color is an interaction between a very small range of electromagnetic waves and the eye and brain of a person. What people call red, green or blue are just ways of categorizing what their brain experiences [5]. Di zenzo proposes the color tensor, derived from the structure tensor, for the computation of the color gradient [6]. Van et al. propose photometric quasi-invariants which have better noise and stability characteristics compared to existing photometric invariants [7]. Combining photometric quasi-invariants with derivative based feature detectors leads to features which can identify various physical causes, e.g. shadow corners and object corners. The theory and practice is reviewed to obtain color invariance such as shading/shadow and illumination invariance incorporated into the color feature detectors. In summary, the methods and techniques solving the following important issues in the field of color feature detection: (i) to obtain color invariance such as shading/shadow, illumination invariance, (ii) to combine derivatives of the different color channels to compute locale image structures such as edges, corners, circles etc., (iii) to select and weight color (invariant) models for discriminatory and robust image feature detection, (iv) to improve color saliency to arrive at color distinctiveness (focus-of-attention), (v) to classify the physical nature of image structures such as shadow, highlight and material edges/corners [8]. Two important criteria for color feature detectors are: (i) (repeatability) they should be invariant (stable) under varying viewing conditions, such as illumination, shading, and highlights; (ii) (distinctiveness) they should have high discriminative power. It has been shown that there exists a trade-off between color invariant models and their discriminative power [9]. For example, color constant derivatives have been proposed which are invariant to all possible light sources assuming a diagonal model for illumination changes. However, such a strong assumption will significantly reduce the discriminative power [10]. For a particular computer vision task that assumes only a few different light sources, color models should be selected which are invariant (only) to these few light sources resulting in an augmentation of the discriminative power.

### 3. Description of system architecture

Detecting color of an object can be an interesting and useful electronic application. It can be realized using a color sensor module like GY-31 TCS3200 and Arduino Uno. TCS3200 chip is designed to detect the color of light incident on it. It has an array of photodiode (a matrix of 8×8, so a total 64 sensors) [11]. These photodiodes are covered with three type of filters. Sixteen sensor have RED filter over them thus can measure only the component of red in the incident light. Likewise, other sixteen have GREEN filter and sixteen have BLUE filter. As any visible color can be broken into three primary colors. So these three type of filtered sensors helps measure the weightage of each of primary colors in incident light. The rest 16 sensors have clear filter. TCS3200 converts the intensity of incident radiation into frequency. The output waveform is a 50% duty cycle square wave [12]. Then if a LCD display is connected to the Arduino Uno, the value of intensity or name of the color will be showed in the display. Thus the color of an object is detected. Working principle of the proposed system was shown in Figure 1.

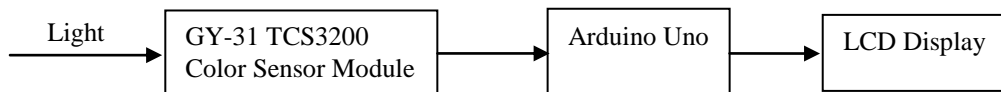

**Fig. 1.** Working principle of proposed system

### 4. Design

#### Design assumptions

- (i). The sensor module GY-31 TCS3200 should be surrounded by a hard paper so that the color of the object can reflect on it properly.
- (ii). Power supply should be 3 to 5 volt.
- (iii). The best detection distance should be 1cm.
- (iv). The sensor should be placed alongside Arduino board.
- (v). The frame size of the device should not exceed 30×20×15 in cm.

Programming was done for color detective device in microcontroller according to the design assumptions of the study.

### Design layout

Layout of the study was shown in Figure 2. And according to the design layout flow chart was shown in Figure 3, which stated that how a color is detected.

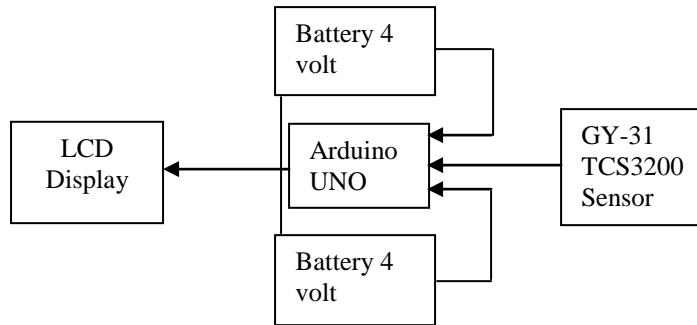

Fig. 2. Layout of the study

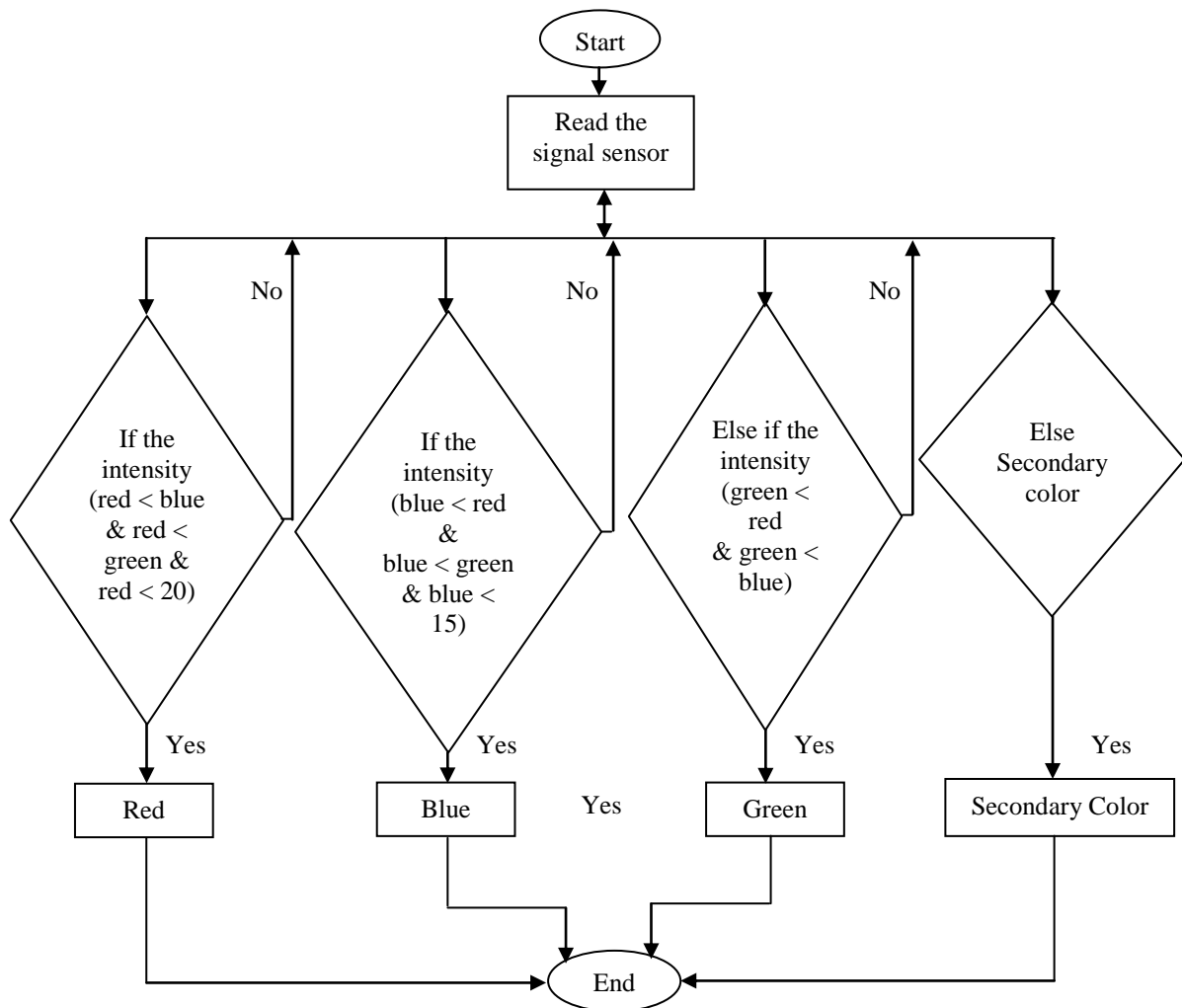

Fig. 3. Flow Chart

## **5. Description of the main components of the system and construction**

### **Arduino UNO**

The study is based on microcontroller board designs, produced by several vendors, using various microcontrollers. These systems provide sets of digital and analog I/O pins that can interface to various expansion boards and other circuits. The boards feature serial communication interfaces, including Universal Serial Bus (USB) on some models, for loading programs from personal computers. For programming the microcontrollers, the Arduino study provides an integrated development environment (IDE) based on a programming language named Processing, which also supports the languages C and C++ [13]. The Uno is a microcontroller board based on the ATmega328P. It has 14 digital input/output pins (of which 6 can be used as PWM outputs), 6 analog inputs, a 16 MHz quartz crystal, a USB connection, a power jack, an ICSP header and a reset button. It contains everything needed to support the microcontroller; simply connect it to a computer with a USB cable or power it with an AC-to-DC adapter or battery to get started.

### **GY-31 TCS3200 color sensor module**

The TCS3200 programmable color light-to-frequency converters that combine configurable silicon photodiodes and a current-to-frequency converter on a single monolithic CMOS integrated circuit. The output is a square wave (50% duty cycle) with frequency directly proportional to light intensity (irradiance) [14]. The full-scale output frequency can be scaled by one of three preset values via two control input pins. Digital inputs and digital output allow direct interface to a microcontroller or other logic circuitry [15]. Output enable (OE) places the output in the high-impedance state for multiple unit sharing of a microcontroller input line.

### **Light-to-frequency converters**

Light-to-Frequency (LTF) Sensors convert light intensity to a digital form for direct interface to a microcontroller. The output of the device is square wave or pulse train whose frequency is linearly proportional to the light intensity. The output voltage is a pulse train and its frequency is directly proportional to the light intensity (irradiance) on the photodiode. Its output is a waveform whose frequency is directly proportional to the light intensity, thereby enabling the device to interface directly to a microprocessor. LTF converters are designed for applications such as ambient light measurement, light absorption/reflection in products such as white goods, photographic equipment, colorimetry, chemical analyzers and display contrast controls or any system requiring a wide dynamic range, and/or high resolution digital measurement of light intensity.

### **LCD display**

LCD (Liquid Crystal Display) screen is an electronic display module and find a wide range of applications. A 16×2 LCD display is very basic module and is very commonly used in various devices and circuits. These modules are preferred over seven segments and other multi segment LEDs. The reasons being: LCDs are economical; easily programmable; have no limitation of displaying special & even custom characters (unlike in seven segments), animations and so on. A 16×2 LCD means it can display 16 characters per line and there are 2 such lines. In this LCD each character is displayed in 5×7-pixel matrix. This LCD has two registers namely, Command and Data [16].

### **Battery**

An electric battery is a device consisting of one or more electrochemical cells with external connections provided to power electrical devices. A battery has a positive terminal, or cathode, and a negative terminal, or anode. The terminal marked positive is at a higher electrical potential energy than is the terminal marked negative. The terminal marked negative is the source of electrons that when connected to an external circuit will flow and deliver energy to an external device. When a battery is connected to an external circuit, electrolytes are able to move as ions within, allowing the chemical reactions to be completed at the separate terminals and so deliver energy to the external circuit [17].

### **Construction**

The whole system was constructed on a wooden frame. Two 4volt battery was mounted on it. Every component was connected via wires with the battery. An Arduino UNO microcontroller with previously programmed was connected with the GY-31 TCS3200 color sensor module. A LCD display is connected with an Arduino UNO through bread board and vero board in which variable resistor 101. The sensor module GY-31 TCS3200 should be surrounded by a hard paper so that the color of the object can reflect on it properly. Hardware design of the color detective was shown in Figure 4.

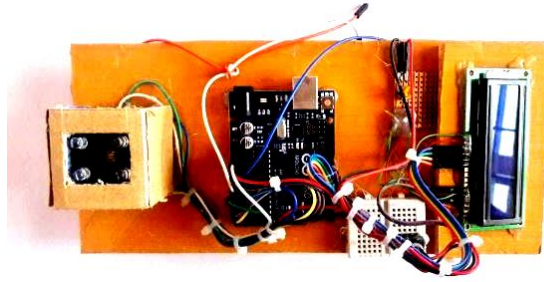

**Fig. 4.** Hardware Design

## 6. Performance result

For testing the performance, different colors were set on the paper. After that a colored paper (acting as an object) was placed on the GY-31 TCS3220 color sensor module. During performance test, primary colors red, green, blue and secondary colors yellow, and cyan, magenta and also black, white colors are detected successfully. The name of the colors was showed in a LCD display which gives accurate color detection that using different color LED. Figure 5 and 6 showed the performance test of the color detective device, where a blue color is detected.

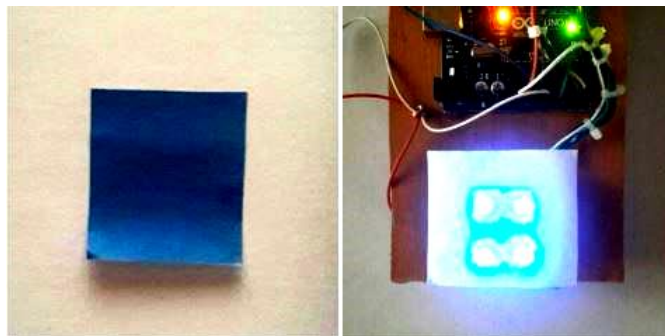

**Fig. 5.** Blue color testing



**Fig. 6.** Performance test for blue color

## 7. Discussion

This study works based on programmable color light-to-frequency converters. The color sensor module GY-31 TCS3200 which measures the intensity of light reflected by a particular colorful object and Arduino run the logic to identify primary (Red, Green, Blue) and secondary (Yellow, Magenta, Cyan) color and also black and white color. In this study, at first LDR (Light-dependent resistor) was used to detect the color but the values of LDRs vary too much and remain unstable with change of little light. So sometimes this color detector system does not work properly. To solve this problem GY-31 TCS 3200 color sensor module was used. For better color detection, TCS 3400 can be used. The TCS3400 provides color and IR (red, green, blue, clear and IR) light sensing. The color sensing provides for improved accuracy lux and color temperature measurements typically used to adjust the backlight intensity and correct the display color.

## 8. References

[1] R. Haralick and L. Shapiro, *Computer and Robot Vision, volume II*. Addison-Wesley, 1992.

- [2] C. Schmid, R. Mohr, and C. Bauckhage, "Evaluation of interest point detectors," *International Journal of Computer Vision*, Vol.37, No.2, pp. 151–172, 2000.
- [3] J. Shi and C. Tomasi, "Good features to track," in *IEEE conference on Computer Vision and Pattern Recognition*, 1994.
- [4] M. Assaad, I. Yohannes, A. Bermak, D. Ginhac and F. Meriaudeau, "Design and characterization of automated color sensor system," *International Journal on Smart Sensing and Intelligent systems*, Vol.7, No.1, pp. 1-12, 2014.
- [5] T. K. Binnar, D. D. Deoghare, P. N. Patil and V. S. Kulkarni, "Designing of RGB Color Detector", *International Journal of Recent Development in Engineering and Technology*, Vol.3, No.2, pp. 12-15, 2014.
- [6] S. D. Zeno, "Note: A note on the gradient of a multi-image," *Computer Vision, Graphics, and Image Processing*, Vol.33, No.1, pp. 116–125, 1986.
- [7] J. V. D. Weijer, T. Gevers, and J. Geusebroek, "Edge and corner detection by photometric quasi-invariants," *IEEE Trans. Pattern Analysis and Machine Intelligence*, Vol.27, No.4, pp. 625–630, 2005.
- [8] T. Gevers, J. V. D. Weijer and H. Stokman, *Color Feature Detection: "Color Image Processing: Emerging Applications," Boca Raton, FL: CRC Press, 2006.*
- [9] T. Gevers and H. Stokman, "Robust histogram construction from color invariants for object recognition," *IEEE Trans. on Pattern Analysis and Machine Intelligence (PAMI)*, Vol.26, No.1, pp. 113–118, 2004.
- [10] T. Gevers and A. W. M. Smeulders, "Color based object recognition," *Pattern Recognition*, Vol.32, No.3 pp. 453–464, 1999.
- [11] [www.circuitdigest.com/microcontroller-projects/arduino-color-sensor-tcs3200](http://www.circuitdigest.com/microcontroller-projects/arduino-color-sensor-tcs3200)
- [12] <http://extremeelectronics.co.in/avr-tutorials/interfacing-tcs3200-colour-sensor-with-avr-atmega32/>
- [13] [www.createspace.com/6736548](http://www.createspace.com/6736548)
- [14] [www.klinikrobot.com/product/color-sensor/tcs3200-color-sensor](http://www.klinikrobot.com/product/color-sensor/tcs3200-color-sensor)
- [15] [www.github.com/MajicDesigns/MD\\_TCS230/blob/master/README.md](https://github.com/MajicDesigns/MD_TCS230/blob/master/README.md)
- [16] [www.engineersgarage.com/electronic-components/16x2-lcd-module-datasheet](http://www.engineersgarage.com/electronic-components/16x2-lcd-module-datasheet)
- [17] [https://en.wikipedia.org/wiki/Battery\\_\(electricity\)](https://en.wikipedia.org/wiki/Battery_(electricity))