

Oil Spillage Problem and A Solution

Syed Tahmid Hussan¹, MD Yeasin Arafat²

^{1,2}Department of Petroleum and Mining Engineering
Chittagong University of Engineering and Technology(CUET)
E-mail: ¹syedtahmid2012@gmail.com

Abstract

Oil spill is the discharge of liquid petroleum into the environment mainly in marine areas which is a dangerous disaster that hits the marine and coastal ecosystem.

On 9 December 2014, an oil spill occurred at Shela river in Sundarban where 350000 liters oil leaked. Crude oil and refined fuel spills from tanker ship accidents have damaged vulnerable ecosystems in Alaska, the Gulf of Mexico, the Galapagos Island, France and many other places. The quantity of oil spilled has ranged from a few hundred tons to several hundred thousand tons.

There are number of oil spill removing systems like surface dispersant system, control burn, sorbent material system, etc. but in most cases, this recovered oil can not be reused.

This research paper presents an effective sample device for removing oil spills which was discovered practically. A brief description about the apparatus, working principal, installment and other related topics are described. A comparison between this device and other oil spill removing system has been studied and recounted why it is better than any other systems.

Keywords: Spill removing device, simple construction, remotely controlled, PIC microcontroller.

1. Introduction

In the present world, oil is still the biggest energy source. Transportation of oil and its derivatives by using tankers or submarine oil pipelines, which increases the probability of oil spillage in the water either by leakage from submarine oil pipeline or accidents with the tankers. In April 2010, the largest oil spill took place at Gulf of Mexico where about 4.9 million barrels oil was spilled [1]. If we just look back to the year 2014, we see that an oil spill occurred Sundarbans, Bangladesh, a UNESCO world heritage site [2].

An oil spill occurring in open or confined sea causes a great ecological damage in the total ecosystem of the area. Many ocean spineless animals and also birds, fish, sea mammals are mostly impacted, and in some cases the whole food chain is affected. Oil spills can directly hamper the physiology, immunology, and development of some organisms, but the most notable effect is an overall decrease of populations of marine fauna and flora within the affected zone. [3]

For many years, oil spill removing methodology has mainly consisted of inadequate mechanical recovery and cleanup, containment with booms, absorption, in situ burning and chemical dispersants agents [4]. Dispersants contains polluting substances that make the environmental impacts of the oil many times more toxic. Burning results in releasing toxins into the atmosphere, along with collection methods that necessitate relocating the toxic elements of a spill to somewhere else, does not remove the spill from the environment. [4]

These limitations have been tried to overcome by the proposed sample device in this paper. The device is a combination of a Bluetooth module, a rotating motor and a belt of net cloth. A microcontroller is used to control the total system. An oiled net cloth is very congenial to suck oil from oil-water contact. This technique is implemented here with a DC motor that conduct the rotary belt where a portion of belt will be contacted with water surface. During operation, the belt will suck oil that is collected by squeezing the belt. This system has no negative impact on environment, totally ecofriendly and has a good efficiency.

2. Conventional spill Removing methods and their Limitations:

a. Surface dispersants

Dispersants are chemical that decompose the oil instantly to smaller droplets. Small droplets are easier to disperse throughout a water volume, also small droplets may be more readily biodegraded by microbes. But Animals dwelling underwater, who may be harmed by toxicity of both dispersed oil and dispersant. Although dispersant reduces the amount of oil that lands ashore, it may allow faster, deeper penetration of oil into coastal terrain, where it is not easily biodegraded. [5]

b. Underwater dispersants

This method is used when spill occurs underwater. A specialized underwater vessel is used to spray the dispersant under the water.

The underwater dispersant may give out toxic substance during decomposition. Also, the use of an underwater vessel at extreme depth is not possible. [4]

c. Burning

The spilled oil is contained using a fireproof boom and the oil is set to fire in a controlled manner. Though oil is removed quickly from the surface of water, the toxic smoke coming out from the fire causes harmful air pollution. [4]

d. Bioremediation

Microorganism like bacteria can eat up the oil and increase the rate of decomposition. On this purpose, sulfates or nitrate fertilizers are added to bacterial colony and once the bacteria start growing it starts decomposing the spilled oil washed up ashore. But the problem is bacterial decomposition is a slow process. [4]

e. Manual Cleanup

This method is the most basic one in which the oil which washed up ashore is removed by manual labor. Workers are put to work on cleaning the shore using shovels and rakes often using the help of bulldozers and tractors. The use of machinery in excess can lead to destruction of biodiversity in the shores. Also, this technique doesn't prevent the oil from spreading into the shore.

f. Gelling agents

These are chemicals that solidify the oil into rubber like material which float on water and can be removed using nets, skimmers etc. But the barrier is the quantity of chemical solidifiers required very high that it is restricted to be used in small to moderate spills.

3. Description of Oil Spill Removing Device:

Design of system components

The whole system is consisting of three individual units- Hoisting unit, collecting unit and Controlling unit. The hoisting unit comprises of oiled net cloth for lifting oil from oil water contiguity. Collecting unit is for accumulating oil and controlling unit consists of micro-controller which controls the motor driver, rpm, Bluetooth driver and time of rotation.

Design of controlling unit

At controlling unit, PIC16F73 is used which is a 26 pin microcontroller of PIC series. Among these pins, 22 input/output pins, 5 analog/digital pins, 2 CCP pins for PWM. It has also USART feature for serial communication. MicroC PRO compiler is used to write the program and PICkit 2 loader is used to load the hex. file of the program to the microcontroller. A 16 MHz oscillator is connected with its 9 and 10 pin to maintain a

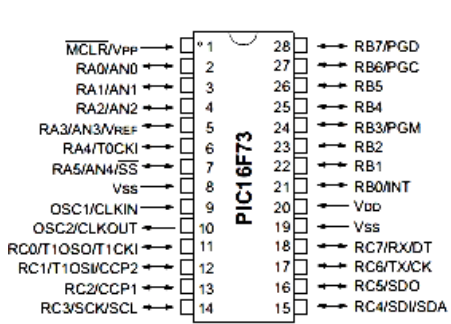

Fig. 1. PIC16F73 Microcontroller

certain frequency.

A DC gear motor is used at this project which can be operated within the range of 5-12 volts and has a speed of 100 RPM. This type of gear motors has high torque and produces very less vibrations effect so that the belt can rotate smoothly. A motor driver of L298N IC model is used to carry out the motor which is monolithic integrated, high voltage, high current 4- channel driver. In this system, a converter is used to step down the 240V AC to 18V, 3-amp DC supply.

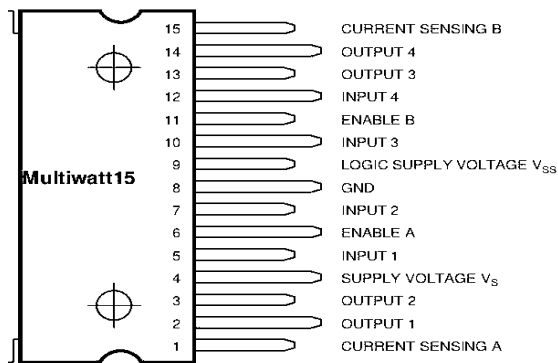

Fig. 2: Motor Driver

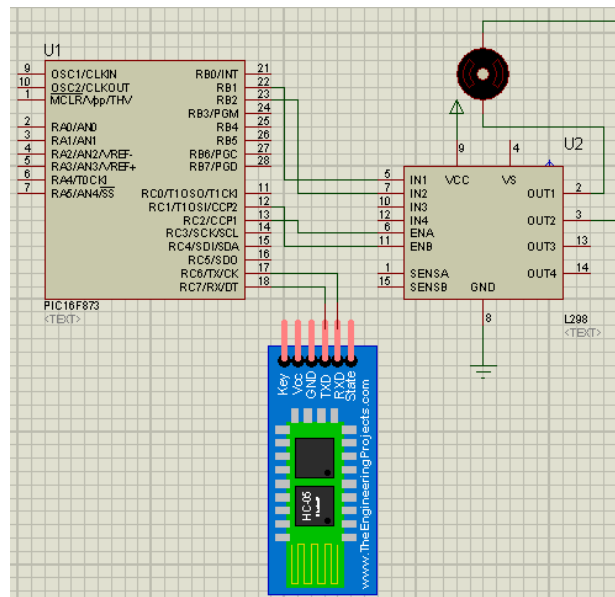

Fig. 3: Pin Connection

A Bluetooth module (HC-05) is used to control the system remotely and to communicate with Bluetooth module, 'Serial Communication' android application is used.

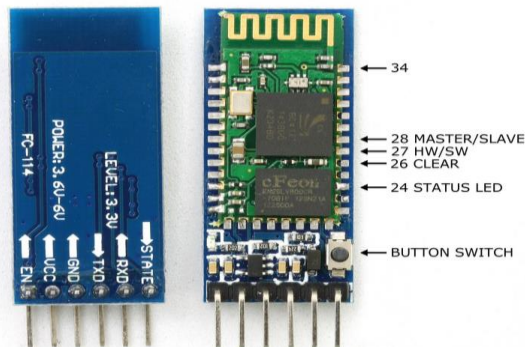

Fig. 3: HC- 05 Bluetooth module

Design of Hoisting and Collecting unit:

As the device is a sample system, we used some common components to develop it. A wooden block of (63 cm × 15 cm) dimension is used as base. Two wheels of 3.4 cm is mounted on the motor. The wheel is covered with rubber belt which is used as squeezer. The motor is fixed with an iron pin that is installed at 41.7 cm away from suction line. The belt remains extended on suction line and become folded just before entering squeezer. Folding and extending is controlled by hook which is mounted by iron pins on wooded base. Extension occurs at 19.3 cm before suction line and folding occurs 5 cm before squeezing unit. The suction line (The portion that is contacted with water surface) is 12 cm. In collecting unit, a plastic canal is installed under squeezing wheel. Oil dropped on the canal and accumulated in a bin.

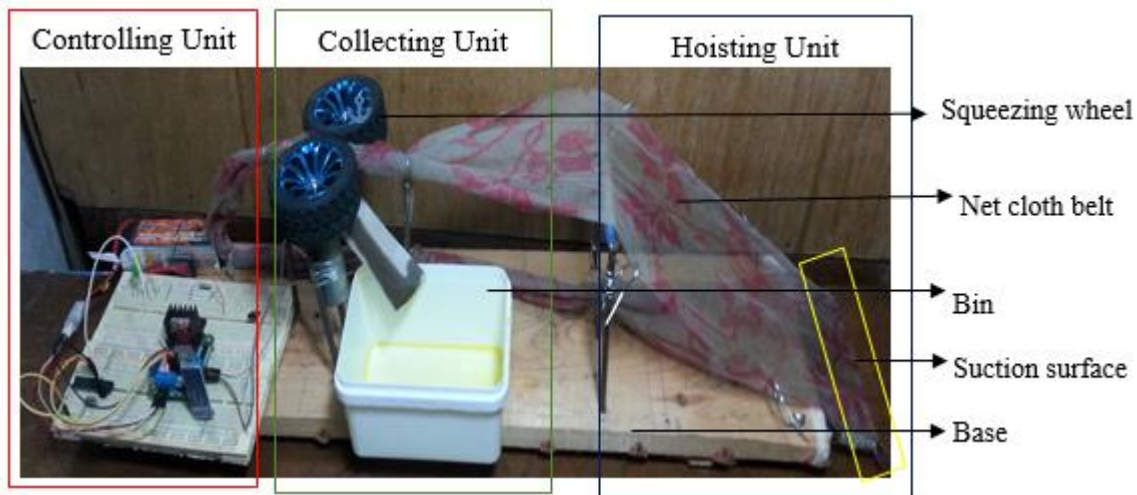

Fig. 4: Constructed Oil spill remover

4. Working Procedure

Consider the system mounted on a boat. When the controller switch on the supply, current is passed to the microcontroller as well as the Bluetooth module. This microcontroller then waits for a signal from Bluetooth module and provides signal to the driver module at a specific time interval. To drive the motor a DRIVER MODULE (L298 D) has been used. It receives the signal coming from the MCU & change the speed of the motor. Rotation of the motor causes moving of belt. The belt is made of net cloth. One portion of the belt is in contact with water surface which is actually the layer of oil. When a signal is sent from android, motor starts rotation with specific rpm and the belt begins moving. This causes the belt to suck oil from oil water contact. The belt becomes folded before passing through the squeezer. The squeezer squeezes the folded belt and oil is accumulated in a bin.

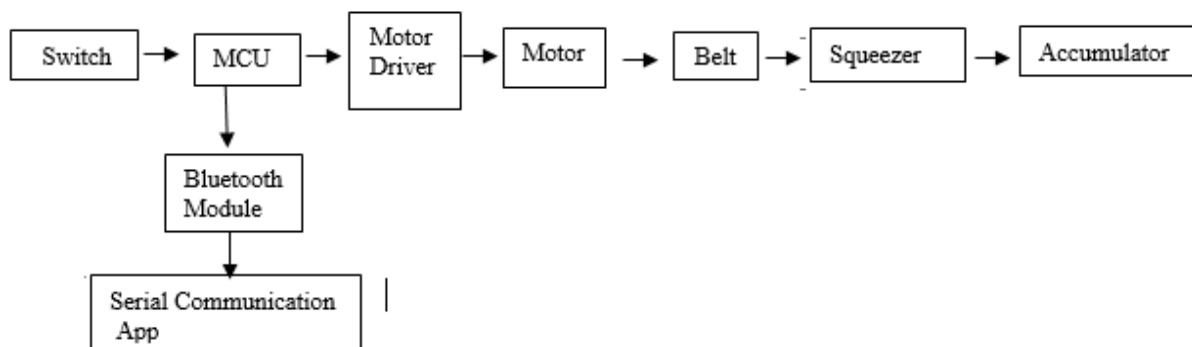

Fig. 5: Flow diagram of working process

5. Data collection

Table 1: Accumulation measurement

Trial No.	Time (s)	Rotation of motor	Accumulation (mL)	% of Oil	%of water
1	60	16	28	92	8
2	60	15	31	85	15
3	60	17	32.5	90	10
4	60	15	30	95	5
5	60	17	31	90	10
6	60	16	31.5	93	7
7	60	16	29	90	10
8	60	17	28.5	91	9
9	60	15	31.5	90	10
10	60	17	31	94	6
Average	60 seconds	16.1 rotations	30.6 mL	91%	9%

6. Result and Discussion

After analyzing above data, we have seen that motor rotates about 16 times in 60 seconds and 30.6 mL of liquid accumulated in the bin where about 91% of oil and only 9% of water remains. This result is for 12 cm suction line. We have got about 510 mL of liquid for 200 cm suction line with previous time interval and rotation speed. We can change motor speed remotely by sending signals through Bluetooth module. Changing of motor speed may depend on the speed of boat.

Now it is a question, why is this system better than other oil removing processes?

a. The first and foremost important reason is the reusability of oil. Accumulated oil has only 9% of water which can be removed easily. Use of dispersants, gelling agents can remove oil spill but we can not reuse the oil or dispersant.

b. Burning is also a conventional spill removing system. But it directly hampers the environment which is contradictory to the purpose of oil spill removing. But this device has no risk of environmental pollution and totally eco-friendly.

c. Boom and skimmers cannot be used in confined areas. But this device can be used in both confined and open area.

d. The device is totally remote controlled. This will reduce the risk while working in the spot.

7. Conclusion

It is concluded that oil spill remover has successfully designed. The system is very simple but have innovative features which reduces barriers to the way of spill removing process. This type of oil spill remover can be used very effectively in oceans as well as river, canal or other confined areas. This machine will reduce time, human effort, cost and increase efficiency and workability. PIC microcontroller was used to construct the device which is very user friendly in programming. On the other hand, to construct the main structure, very simple tool work is needed and the materials used in this project is cheap and available in market. It has no risk of environmental pollution, no use of chemical dispersants or gelling agents and no limitation of using only in confined areas. The use of simple net cloth as belt reduces all the limitations. A special feature of this device is the reusability of spilled oil which can reduce the industrial losses due to oil spill. My strong belief is that further improvement of this device would be an innovation in spill removing process.

8. References

- [1] GowthamRajagopal, RahulNath.R, Savin Viswanathan, Satheesh Babu P K “Determination of Efficient Recovery Methods Based on Nature of Spilled Oil” pp 1
- [2] “2014 Sundarbans oil spill.” available at https://en.wikipedia.org/wiki/2014_Sundarbans_oil_spill (September 2017)
- [3] David R. Vieites, Sandra Nieto-Roman, Antonio Palanca, Xavier Ferrer, Miguel Vences, “European Atlantic: the hottest oil spill hotspot worldwide.” pp 530-540
- [4] Lawrence Anthony Earth Organization (LAEO) “A Call for a Twenty First Century Solution in Oil Spill Response” In observance of Earth Day 2015 and the 5th anniversary of the Deepwater Horizon Gulf of Mexico oil spill disaster, pp 2-5.
- [5] Markus Huettel, Alissa Zuijidgeest, “Dispersants Can Move Hydrocarbons Faster and Deeper into Gulf Sand” available at <http://gulfresearchinitiative.org/study-dispersants-can-move-hydrocarbons-faster-and-deeper-into-gulf-sand/> (September 2017)