

## Automatic Whiteboard Cleaner Using Microcontroller Based Rack and Pinion Mechanism

Sonia Akhter\*, Anindo Saha, Md. Rayhan Parvez Koushik, Md. Asaduzzaman, Razoana Islam Shorna, Md. Moudud Ahmed  
Department of Industrial & Production Engineering  
Rajshahi University of Engineering & Technology (RUET), Rajshahi-6204, Bangladesh  
\*Corresponding Author: E-mail: sonia\_ruet@yahoo.com

### Abstract

*At recent years whiteboard has become a crucial element at almost every educational institute. They are large in size, for that reason it is very time consuming and tedious process to erase the writings from the board with duster manually. It breaks concentration of both lecturers and listeners. Automatic Whiteboard Cleaner can solve these problems. Automatic whiteboard cleaner will reduce the time and also the effort. It takes around 6secs to clear the board smoothly. This paper represents the design and construction of automatic whiteboard cleaner. The system consists of Arduino microcontroller, driver module, dc gear motor, rack and pinion mechanism, sonar sensor, supports, and a cleaner bar to give that an automation figure. When the switch is on, it moves across the full width of the board and its direction is reversed automatically in order to clean the board. So, this "Automatic Whiteboard Cleaner" is a great replacement of "duster" and it can be suggested to use this to reduce the effort of the board user as well as to introduce the classroom with an automation system.*

Key words: Automation, whiteboard cleaner, arduino, rack and pinion mechanism, sonar sensor.

### 1. Introduction

Education is the back bone of a nation. Education comprises of teaching and learning. The resources and materials used in teaching becoming updated along with the teaching and learning techniques. Writing was earlier done on sand, walls, slates made out of wood, chalkboards and in recent times on white boards and electronic boards [1]. Chalk dust scatter causes serious health problems. Because of these reasons white board has been widely implemented into many other sectors of human endeavor besides teaching [2].

Many researches and testing had been done on white board from a long time. Many variations had been done on cleaning of whiteboard surfaces. Remote control motorized cleaners are made in which the dusters are operated with the help of remote control [1]. This type of cleaner moves horizontally by means of motor mechanism and erase the board with the help of dusters attached to it but it could not create sufficient pressure on board. This limitation was solved by using rolling whiteboard surface and fixed dusters [3]. Instead of moving the dusters the whiteboard surface is moved around the rollers. The friction produced between fixed dusters and rolling surface creates sufficient pressure to erase the written data on it but this process is too time consuming to clean the board. This drawback was overcome by using microcontroller and sensors but the longevity of board surface is short because it acts as flat belt [4]. Remote control motorized cleaners makes use of belts which have low wear and tear resistance and with the frequent operation of cleaning process, the belt is likely to cut and hence makes the device or the cleaner less useful [3], [4]. Instead of belt, chain had been used to improve the cleaning procedure but it creates too much noise [5]. Using cord and pulley arrangement the wiper bar connected to the motors can erase writings on the board which creates less noise but it requires four motors and two motor drivers causing too much cost [6]. These limitations have been overcome by the proposed design in this paper. Only one motor and one motor driver with rack and pinion mechanism is used instead of belts and large amount of pressure has provided by rack and pinion mechanism with necessary supports.

### 2. System components

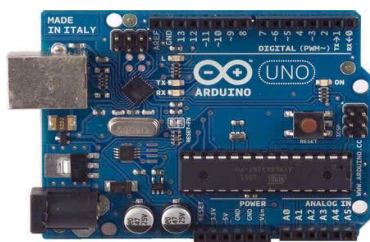
This system is designed considering the present scenario of white boards. It consists of seven main components. They are dc gear motors, arduino UNO, motor driver, wooden block, duster holders, dusters, rack & pinion mechanism, AC to DC converter and whiteboard surface.

### 3. Design of system components

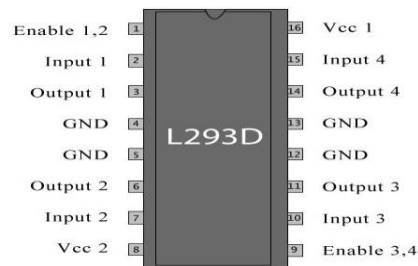
The whole system is based upon two individual units. One is the cleaning unit which ensures to erase writings and other is the controlling unit which controls the cleaning system. The cleaning unit consists of the necessary arrangement which enable the cleaner slide over the board and the controlling unit consists of micro-controller which controls the motor, rpm, and the time of rotation.

#### Design of controlling unit

At controlling unit Arduino Uno is used which is a microcontroller board based on the ATmega328 .It has 14 digital input/output pins (of which 6 can be used as PWM outputs), 6 analog inputs, a 16 MHz ceramic resonator, a USB connection, a power jack, an ICSP header, and a reset button. One of its most important features is its ease of programmability. Motor Driver of L293D IC model is used which is a monolithic integrated, high voltage, high current, 4-channel driver. Using chip it is possible to use DC motors and power supplies of up to 36 Volts and maximum current of 600mA per channel.

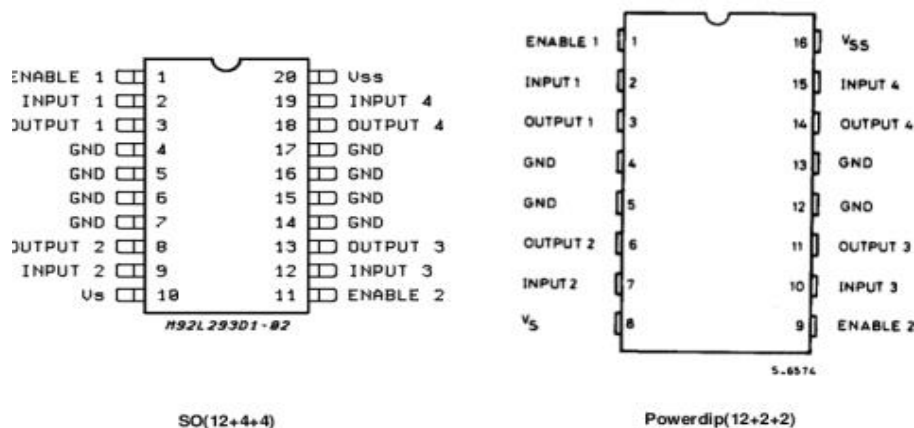


**Fig.1.** Arduino UNO Microcontroller



**Fig.2.** Motor driver

A dc gear motor is used at this project which can be operated within the range of 4V - 24V and has a speed of 100 RPM. The shaft length of motor is 25-30 mm and shaft diameter is 8 mm. This type of gear motors has high torque and produces very less vibration effect so that the pinion can rotate smoothly. AC to DC adapter is used to convert AC supply into DC supply. In this system the converter is used to step down the 240V AC to 18V, 3 amp DC supply. The converter is required for functioning of DC gear motors because these motors work only on dc supply. Sonar Sensor or Ultrasonic Range Sensor (HC-SR04) is used to calculate the distance between the sensor and the reflecting object mounted at brush. Pin connection of both motor driver and arduino UNO has shown at fig. 3.



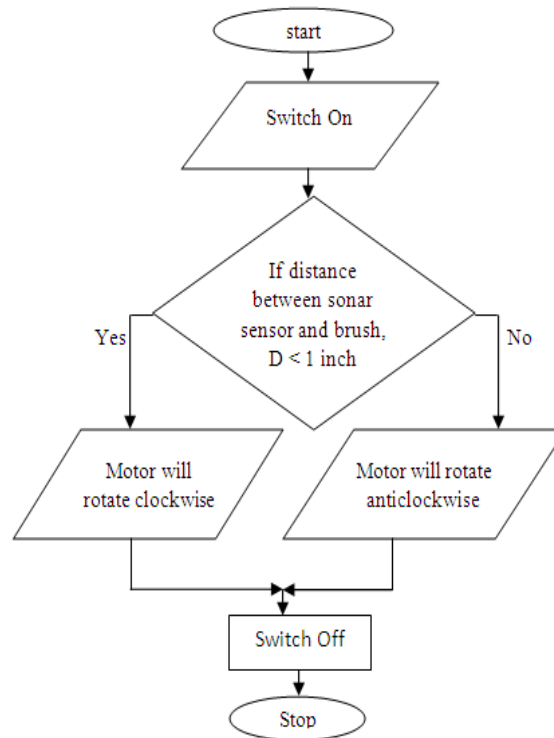
**Fig.3.** Pin connection of Arduino UNO and Motor Driver

As shown in the figure above, it's possible to drive 2 motors with a single L293D but only 1 motor is used at this project. Table 1 shows how to make the motor turn clockwise and anti-clockwise. For example, if the pins 1 and 7 are in HIGH state, and the pin 2 in the LOW, the motor will rotate clockwise. On the other hand, if the pins 1 and 2 are in HIGH, and the pin 7 in the LOW, the motor will turn to the other way. Signal from sonar sensor will change the state of pin 2 and pin 7.

**Table 1.** Combination of pin status to make the motor run clockwise and anti-clockwise

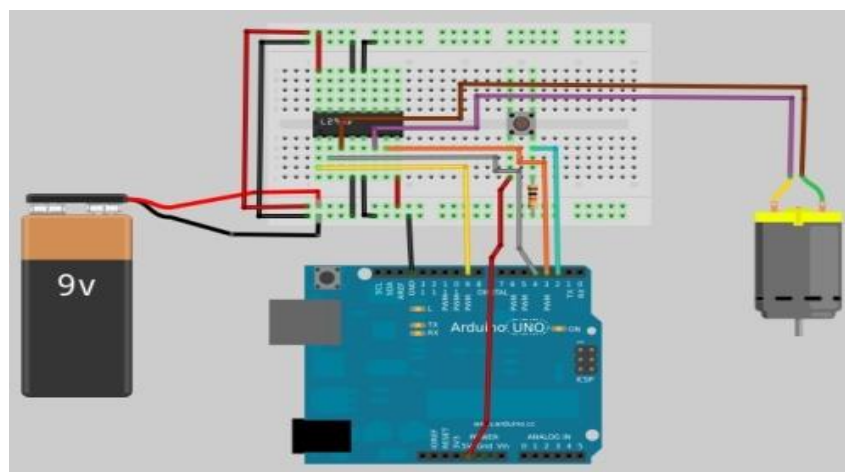
Pin 1	Pin 2	Pin 7	Function
High	Low	High	Turn clockwise
High	High	Low	Turn anticlockwise
High	Low	Low	Stop
High	High	High	Stop
Low	Not applicable	Not applicable	Stop

If the distance between the sonar sensor and brush is less than 1 inch then motor will rotate clockwise and if this distance is greater than 1 inch then motor will rotate anticlockwise which is programmed into the microcontroller. The flow chart of motor rotation has shown below.



**Fig.4.** Flow chart of motor rotation

Main circuit diagram of automatic whiteboard cleaner has shown below which comprises of arduino, motor driver, 9v dc gear motor and sonar sensor. 18v dc gear motor has used in the final project instead of 9v dc gear motor.



**Fig.5.** Design of main circuit of Automatic whiteboard cleaner

## Design of cleaning unit

Cleaning unit consists of rack and pinion, brush, whiteboard, supportive board etc. Rack and pinion mechanism consists of a circular pinion of a diameter of 1.5 inches and long rectangular rack of a length of 18 inches. The pinion is coupled with the motor that means the pinion rotates with the shaft of the motor. The rotary motion of the motor is transferred to the rack & the rack moves in translatory direction. The brush is an important part for this project. To clean the white board smoothly a brush of better quality has been used. It has attached to the brush holder with the help of glue & the brush holder is attached to the end of the rack with a nut & bolt. Foam has been used as the cleaner. An amonyte sheet of 10 inches × 6 inches size has been used as a white board. The whiteboard is enclosed within two reels. A wooden block is used as a supporting base for the whole system and is made up of plywood. It is of length 50cm, breadth 5cm and height 40cm. It is used to support the whiteboard sheet at the time of writing. The motor and rack & pinion mechanisms are also fitted on wooden block. The reels are fixed with this supportive board by the help of angle plate.

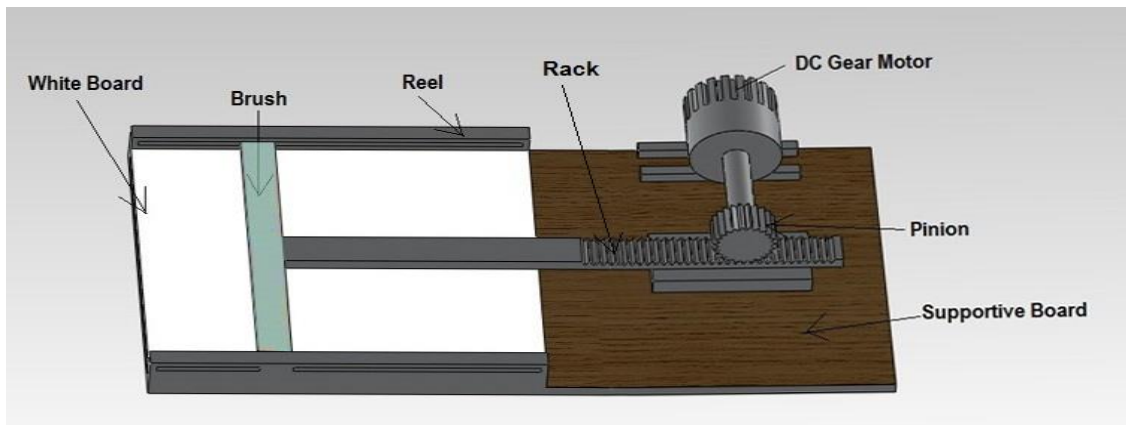


Fig.6. Complete design of an automatic whiteboard cleaner

## 4. Construction of main structure

The system is assembled by using all the components as mentioned above. The duster holders with the dusters fixed in it are attached on backside of the wooden block. A DC gear motor (18V) is fixed on the upper side of the wooden block with clamp. The pinion is coupled with the motor that means the pinion rotates with the shaft of the motor.

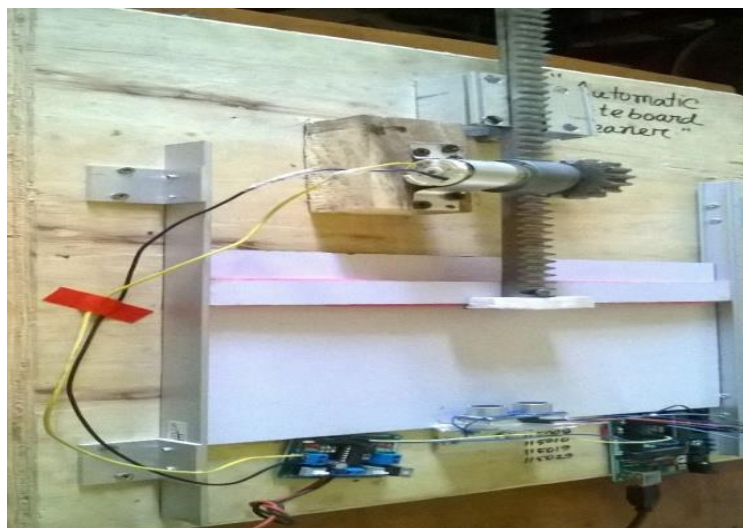


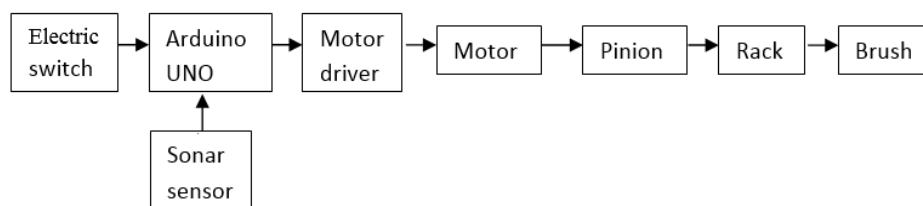
Fig.7. Constructed Automatic whiteboard cleaner

The rotary motion of the motor is transferred to the rack & the rack moves in translatory direction. A brush has been attached to the brush holder with the help of glue & the brush holder is attached to the end of the rack with

a nut & bolt. The flexible white board surface is fixed on the wooden block enclosed with reels. The sonar sensor is fixed on the lower portion of whiteboard attached with angle plate.

## 5. Working procedure

Now, considering the system is in use and the teacher wants to rub the board. When the teacher switch on the supply, current is passed to the 18V adapter and then it passes through Arduino. This ARDUINO provides signal to the driver module at a specific time interval. To drive the motor a DRIVER MODULE (L293D) has been used. It receives the signal coming from the ARDUINO & change the polarity of the motor for which the direction of the motor changes. To sense the distance and time specified by ARDUINO, a sonar sensor is used, hence the motor rotates in both clock-wise & anti-clockwise direction. Due to the rotation of the shaft of the motor, the pinion connected to it also rotates which in turn the rack moves in translatory direction along the whiteboard. A brush holder is attached to the end of the rack with a nut & bolt. To clean the white board smoothly a brush of better quality has been used which is attached to the brush holder. The brush moves from the upper portion to the lower portion of the board and get rubbed due to the friction between board surface and brush.



**Fig.8.** Flow diagram of power transmission of whiteboard cleaner

## 6. Time analysis

Prototype board of 10 inch wide and 6 inch long has been used in this project. Using manual duster it takes about 25 secs for whole board cleaning. Proposed automatic whiteboard cleaner reduces the time requirement. When switch is on, firstly brush moves downward and then moves upward direction thus completes one full cycle of movement. Proposed automatic brush needs 5 full cycles for cleaning the board completely which takes only 6 secs. Several data had taken to determine the time requirement for completing the wiping process. Table-1 shows the time for ten observations.

**Table 2:** Time requires for complete cleaning

Trial No n	Downward Motion Time (Sec), D	Upward Motion Time (Sec), U	Total Time of 1 cycle (sec), T	Average Time (sec), A=T/n	Total average time for complete cleaning (Sec), T.A.T= A * no. of cycles
1	0.57	0.59	1.16	1.195	1.195× No of cycles=1.195×5=5.975
2	0.58	0.61	1.19		
3	0.55	0.60	1.15		
4	0.64	0.62	1.26		
5	0.56	0.63	1.19		
6	0.57	0.59	1.16		
7	0.63	0.61	1.24		
8	0.60	0.60	1.20		
9	0.59	0.62	1.21		
10	0.58	0.61	1.19		

## 7. Result and discussion

It is observed that the time of complete cleaning of the board using this system is average 5.975 sec. On the other hand while using the manual process the time of cleaning is about 25 sec which is about four times of the machine time. So proposed whiteboard cleaner takes less time than other previous models. It creates less noise than other motorized cleaners. Sufficient pressure has been induced during the operation due to the attachment of brush to the side reels of whiteboard which helps to clean the board very effectively and efficiently. Change of brush is very easy and it does not affect any other parts while changing. This system is only applicable to whole board cleaning. Partial cleaning of the board is not possible through this system. Though there is some lagging in to start the motor, but averagely it is optimum.

## 8. Conclusions

It is concluded that automatic whiteboard cleaner has successfully designed. The system has designed with innovative features which reduces human efforts and makes teaching efficient. This type of whiteboard could be very effectively used in schools, colleges and universities as it increases the interest of the students to study with different technology. The machine has reduced both time and human effort. The construction of automatic whiteboard cleaner consists of arduino microcontroller which is very user friendly in programming. On the other hand to construct the main structure, very simple tool work is needed, and the materials used in this project is cheap and easily available in market. So it is not complicated to construct this machine and it will help to introduce an automation system. The system can be further developed by integrating a bluetooth remote for controlling the switch. Infrared sensors can be used to convert this system to a smart white board. Aesthetic looks of the whiteboard can also be improved.

## 8. References

- [1] Tsado Jacob, "A Remote Controlled Motorized White Board Cleaner", *AU Journal of Technology*, Vol.15, No.4, pp. 273-280, 2012.
- [2] Praveen. G, "Microcontroller Based Automatic Electronic Duster", *Proceedings Of International Academic Conference On Electrical, Electronics And Computer Engineering*, pp. 10-13, 2013.
- [3] Puneet Mathur et. al., "Automated Motorized Whiteboard", *International Journal Of Engineering, Business And Enterprise Applications (IJEBA)*, Vol.6, No.1, pp. 01-04, 2013.
- [4] Bhushan Tukaram Chougule and Puneet Mathur, "Automated Motorized Sensing Whiteboard", *International Journal Of Advanced Research In Engineering And Technology (IJARET)*, Vol. 5, No. 3, pp. 155-163, 2014.
- [5] Simolowo and O. E., "Preliminary Design of an Automated White Board Cleaner", *International Multidisciplinary Journal*, Vol. 8 (2), No. 33, pp. 68-82, 2014.
- [6] Imam-Ul-Ferdous and A.H.M Fazle Elahi, "Development of an Automatic Board Cleaning system using Microcontroller", *International Conference on Mechanical, Industrial and Energy Engineering 2014 (ICMIEE: PI-140307)*, Khulna, Bangladesh.
- [7] Chris Betcher and Mal lee, "The Interactive Whiteboard Revolution", *Aust Council for Ed Research*, pp. 10-12, 2009.
- [8] Shmuylovich and Salcman, "Whiteboard Presentation of Interactive and Expandable Modular Content," U.S.Patent 057106 A2, Sept. 07, 2012.

